

QUESTION 1/VRAAG 1

- 1.1 A ✓✓ (2)
1.2 A ✓✓ (2)
1.3 D ✓✓ (2)
1.4 C ✓✓ (2)
1.5 B ✓✓ (2)
1.6 C ✓✓ (Accept/ Aanvaar R) (2)
1.7 A ✓✓ (2)
1.8 D ✓✓ (2)
1.9 A ✓✓ (2)
1.10 C ✓✓ (2)
- [20]**

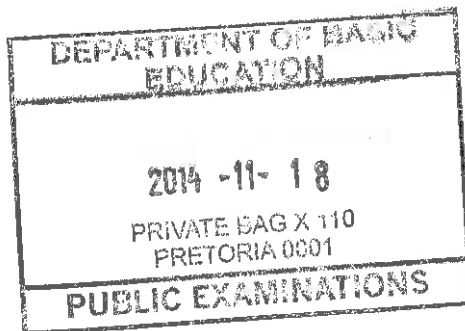

QUESTION 2/VRAAG 2

- 2.1 When a resultant (net) force acts on an object, the object will accelerate in the direction of the force. This acceleration is directly proportional to the force ✓ and inversely proportional to the mass of the object. ✓

Wanneer 'n resulterende (netto) krag op 'n voorwerp inwerk, sal die voorwerp in die rigting van die krag versnel. Hierdie versnelling is direk eweredig aan die krag en omgekeerd eweredig aan die massa van die voorwerp.

OR/OF

The net force acting on an object is equal to the rate of change of momentum ✓✓ of the object (in the direction of the force). (2 or 0)

Die netto krag wat op 'n voorwerp inwerk is gelyk aan die tempo van verandering in momentum van die voorwerp (in die rigting van die krag). (2 of 0) (2)

Blr *R*
RN
S

2.2

Accepted Labels/Aanvaarde benoemings	
w	F_g/F_w /force of Earth on block / weight/49 N / mg / gravitational force F_Q/F_w /krag van Aarde op blok/gewig/49 N / mg / gravitasiekrag
T_2	Tension 2 / F_Q / 250 N / F_{T2} / F_{app} Spanning 2/ F_Q / 250 N / F_{T2} / $F_{toegepas}$
T_1	Tension 1 / F_{T1} / F_P Spanning 1 / F_{T1} / F_P

Accept/Aanvaar: Force diagram/kragtediagram

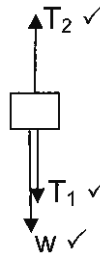
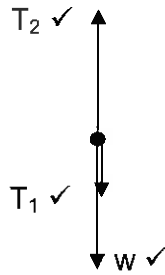

(3)

Notes/Aantekeninge

- Mark awarded for label and arrow / Punt toegeken vir benoeming en pyltjie
- Do not penalise for length of arrows since drawing is not to scale. *!Moenie vir die lengte van die pyltjies penaliseer nie aangesien die tekening nie volgens skaal is nie*
- Any other additional force(s) / Enige ander addisionele krag(te) Max/Maks $\frac{2}{3}$
- If force(s) do not make contact with body / Indien krag(te) nie met die voorwerp kontak maak nie: Max/Maks: $\frac{2}{3}$

2.3

OPTION 1/OPSIE 1

$F_{net} = ma$ ✓

For 5 kg block/Vir 5 kg-blok

$T_2 + (-mg) + (-T_1) = ma$

$250 - (5)(9,8) - T_1 = 5a$ ✓

$201 - T_1 = 5a$

$T_1 = 201 - 5a \dots \dots (1)$

✓ for either/ vir of / 5a or/of 20a

For 20 kg block/Vir 20 kg-blok

$T_1 + (-mg) = ma \dots \dots (2)$

$T_1 + [-20(9,8)] = 20a$ ✓

$5 = 25a$

$a = 0,2 \text{ m}\cdot\text{s}^{-2}$ upwards/opwaarts

$\therefore T_1 = 201 - 5(0,2)$ ✓

$= 200 \text{ N}$ ✓

OR/OF $T_1 = 20(9,8) + 20(0,2)$ ✓

$= 200 \text{ N}$ ✓

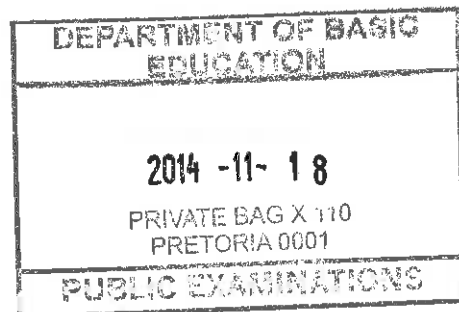

(6)

Handwritten signatures and initials: P.N., S., and other marks.

OPTION 2 / OPSIE 2

$F_{net} = ma$ ✓

For 5 kg block / Vir 5 kg-blok

$T_2 + (-mg) + (-T_1) = ma$

$250 - (5)(9,8) - T_1 = 5a$ ✓

$201 - T_1 = 5a$

$T_1 = 201 - 5a$ (1)

✓ for either / vir of / 5a or / of 20a

For 20 kg block / Vir 20 kg-blok ,

$T_1 + (-mg) = ma$ (2)

$T_1 + [-20(9,8)] = 20a$ ✓

(1) x 4 : $4T_1 = 804 - 20a$

∴ $T_1 - 196 = 804 - 4T_1$ ✓

∴ $5T_1 = 1000$

∴ $T_1 = 200\text{ N}$ ✓

(6)

OPTION 3 / OPSIE 3

$F_{net} = ma$ ✓

For 5 kg block / Vir 5 kg-blok

$T_2 + (-mg) + (-T_1) = ma$

$250 - (5)(9,8) - T_1 = 5a$ ✓

$201 - T_1 = 5a$

$T_1 = 201 - 5a$ (1)

✓ for either / vir of / 5a or / of 20a

∴ $a = \frac{201 - T_1}{5}$

For 20 kg block / Vir 20 kg-blok ,

$T_1 + (-mg) = ma$ (2)

$T_1 + [-(20)(9,8)] = 20a$ ✓

∴ $T_1 - 196 = 20\left(\frac{201 - T_1}{5}\right)$ ✓

∴ $T_1 = 200\text{ N}$ ✓

(6)

Notes / Aantekeninge

Learners need not show how (1) and (2) were combined.

Leerders hoef nie aan te toon hoe (1) en (2) gekombineer is nie.

2.4 Q ✓

(1)
[12]

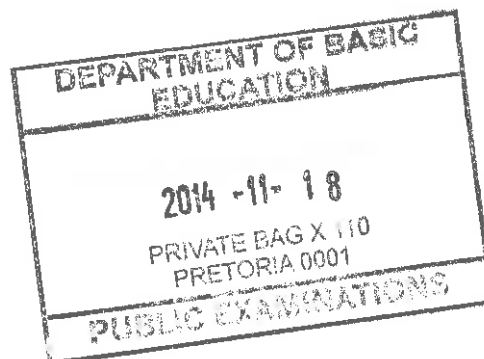

Handwritten signatures and initials:
 P.N.
 B
 8

QUESTION 3/VRAAG 3

- 3.1 An object moving / Motion under the influence of gravity / weight / gravitational force only (and there are no other forces such as friction). ✓✓ (2 or/of 0)
(’n Voorwerp wat / Beweging slegs onder die invloed van swaartekrag / gewig / gravitasiekrag (en daar is geen ander kragte soos wrywing nie). (2)

Notes/Aantekeninge

An object falling at $9,8 \text{ m}\cdot\text{s}^{-2}$ / ’n Voorwerp wat teen $9,8 \text{ m}\cdot\text{s}^{-2}$ val
Max/Maks $\frac{1}{2}$

- | | |
|------------------------------------------------------------------------------------------------------------------------------------------------------------------------------------------------------------------------------------------------------------------------------------------------------------------------------------------------------------|------------------------------------------------------------------------------------------------------------------------------------------------------------------------------------------------------------------------------------------------------------------------------------------------------------------------------|
| <p>3.2 OPTION 1/OPSIE 1
Upwards positive/Opwaarts positief:</p> <p>$\Delta y = v_i \Delta t + \frac{1}{2} a \Delta t^2$ ✓
 $0 \checkmark = 15 \Delta t + \frac{1}{2} (-9,8) \Delta t^2$ ✓
 $\Delta t = 3,06 \text{ s}$
 It takes/Dit neem $3,06 \text{ s}$ ✓</p> | <p>Downwards positive/Afwaarts positief:</p> <p>$\Delta y = v_i \Delta t + \frac{1}{2} a \Delta t^2$ ✓
 $0 \checkmark = -15 \Delta t + \frac{1}{2} (9,8) \Delta t^2$ ✓
 $\Delta t = 3,06 \text{ s}$
 It takes/Dit neem $3,06 \text{ s}$ ✓</p> |
|------------------------------------------------------------------------------------------------------------------------------------------------------------------------------------------------------------------------------------------------------------------------------------------------------------------------------------------------------------|------------------------------------------------------------------------------------------------------------------------------------------------------------------------------------------------------------------------------------------------------------------------------------------------------------------------------|
- (4)

Notes/Aantekeninge

Accept/Aanvaar

g or/of a

$\Delta x = v_i \Delta t + \frac{1}{2} a \Delta t^2$ ✓

$s = ut + \frac{1}{2} at^2$

Ball A: Can work from top down: $v_i = 0 \text{ m}\cdot\text{s}^{-1}$, $v_f = 15 \text{ m}\cdot\text{s}^{-1}$

Bal A: Kan vanaf topunt afwaarts werk $v_i = 0 \text{ m}\cdot\text{s}^{-1}$, $v_f = 15 \text{ m}\cdot\text{s}^{-1}$

OPTION 2/OPSIE 2

Upwards positive/Opwaarts positief:

$v_f = v_i + a \Delta t$ ✓

$0 \checkmark = 15 + (-9,8) \Delta t$ ✓

$\Delta t = 1,53 \text{ s}$

It takes (2)(1,53) = $3,06 \text{ s}$ ✓

Downwards positive/Afwaarts positief:

$v_f = v_i + a \Delta t$ ✓

$0 \checkmark = -15 + (9,8) \Delta t$ ✓

$\Delta t = 1,53 \text{ s}$

It takes/Dit neem $3,06 \text{ s}$ ✓

(4)

Notes/Aantekeninge

At maximum height $v_f = 0$: By maksimum hoogte: $v_f = 0$:

Accept/Aanvaar

g or/of a

$v = u + at$

OPTION 3 / OPSIE 3

Upwards positive/Opwaarts positief:

$v_f = v_i + a \Delta t$ ✓

$-15 \checkmark = 15 + (-9,8) \Delta t$ ✓

$\Delta t = 3,06 \text{ s}$ ✓

Downwards positive/Afwaarts positief:

$v_f = v_i + a \Delta t$ ✓

$15 \checkmark = -15 + (9,8) \Delta t$ ✓

$\Delta t = 3,06 \text{ s}$ ✓

(4)

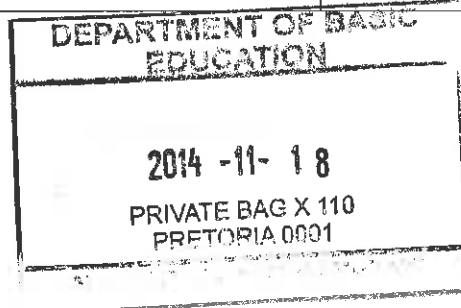

Handwritten initials and signatures: B, P.N., and other marks.

Notes/Aantekeninge

When it returns to same level its speed is $15 \text{ m}\cdot\text{s}^{-1}$.
Wanneer dit na dieselfde vlak terugkeer is sy spoed $15 \text{ m}\cdot\text{s}^{-1}$.

Accept/Aanvaar
g or/of a
 $v = u + at$

OPTION 4/OPSIE 4

Upwards positive/Opwaarts positief:

$$F_{\text{net}} \Delta t = \Delta p \checkmark$$

$$mg \Delta t = m (v_f - v_i)$$

$$\Delta t = \frac{(0 - 15) \checkmark}{-9,8 \checkmark}$$

$$\Delta t = 1,53 \text{ s}$$

It takes/Dit neem $(2)(1,53\text{s}) = 3,06 \text{ s} \checkmark$

Downwards positive /Afwaarts positief:

$$F_{\text{net}} \Delta t = \Delta p \checkmark$$

$$mg \Delta t = m (v_f - v_i)$$

$$\Delta t = \frac{0 - (-15) \checkmark}{9,8 \checkmark}$$

$$\Delta t = 1,53 \text{ s}$$

It takes/Dit neem $(2)(1,53\text{s}) = 3,06 \text{ s} \checkmark$

(4)

Notes/Aantekeninge

At maximum height $v_f = 0$: / By maksimum hoogte: $v_f = 0$:

Accept/Aanvaar
g or/of a

$ma = m (v - u)$
Any one of the two formulae./ Enigeen van die twee formules.

OPTION 5/OPSIE 5

Upwards positive/Opwaarts positief:

$$F_{\text{net}} \Delta t = \Delta p \checkmark$$

$$mg \Delta t = m (v_f - v_i)$$

$$\Delta t = \frac{-15 - (15) \checkmark}{-9,8 \checkmark}$$

$$= 3,06 \text{ s} \checkmark$$

Downwards positive/Afwaarts positief:

$$F_{\text{net}} \Delta t = \Delta p \checkmark$$

$$mg \Delta t = m (v_f - v_i)$$

$$\Delta t = \frac{15 - (-15) \checkmark}{9,8 \checkmark}$$

$$\Delta t = 3,06 \text{ s} \checkmark$$

(4)

Notes/Aantekeninge

When it returns to same level its speed is $15 \text{ m}\cdot\text{s}^{-1}$ /Wanneer dit na dieselfde vlak terugkeer is sy spoed $15 \text{ m}\cdot\text{s}^{-1}$.

Accept/Aanvaar
g or/of a

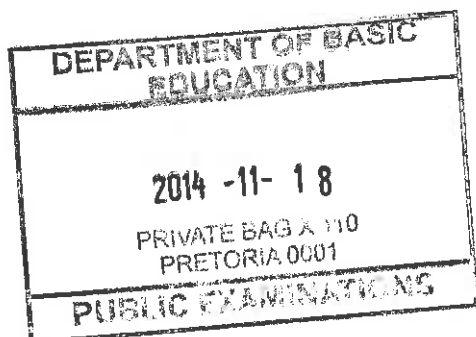

Handwritten signatures and initials: P.N., P.B., and other marks.

OPTION 6/OPSIE 6

**ALL OPTIONS FROM QUESTION 3.3 TO CALCULATE $\Delta y = 11,48$ m
ALLE OPSIES VANAF VRAAG 3.3 OM $\Delta y = 11,48$ m TE BEREKEN**

Upwards positive/Opwaarts positief:

$$v_f^2 = v_i^2 + 2a\Delta y \checkmark$$

For ball A/Vir bal A

$$0 = (15)^2 + 2(-9,8)\Delta y \checkmark$$

$$\Delta y_A = 11,48 \text{ m}$$

$$\Delta y = \left(\frac{v_f + v_i}{2} \right) \Delta t$$

$$11,48 = \left(\frac{15 + 0}{2} \right) \Delta t \checkmark$$

$$\Delta t = 1,53 \text{ s}$$

It takes/Dit neem $(2)(1,53\text{s}) = 3,06 \text{ s} \checkmark$

Downwards positive/Afwaarts positief:

$$v_f^2 = v_i^2 + 2a\Delta y \checkmark$$

For ball A/Vir bal A

$$0 = (-15)^2 + 2(9,8)\Delta y \checkmark$$

$$\Delta y_A = -11,48 \text{ m}$$

$$\Delta y = \left(\frac{v_f + v_i}{2} \right) \Delta t$$

$$-11,48 = \left(\frac{-15 + 0}{2} \right) \Delta t \checkmark$$

$$\Delta t = 1,53 \text{ s}$$

It takes/Dit neem $(2)(1,53\text{s}) = 3,06 \text{ s} \checkmark$

(4)

Notes/Aantekeninge

Ball A: Can work from top down: $v_i = 0 \text{ m}\cdot\text{s}^{-1}$, $v_f = 15 \text{ m}\cdot\text{s}^{-1}$
Bal A: Kan vanaf top punt afwaarts werk $v_i = 0 \text{ m}\cdot\text{s}^{-1}$, $v_f = 15 \text{ m}\cdot\text{s}^{-1}$

3.3

**POSITIVE MARKING FROM QUESTION 3.2
POSITIEWE NASIEN VANAF VRAAG 3.2**

OPTION 1/OPSIE 1

Upwards positive/Opwaarts positief:

$$v_f^2 = v_i^2 + 2a\Delta y \checkmark$$

For ball A/Vir bal A

$$0 = (15)^2 \checkmark + 2(-9,8)\Delta y \checkmark$$

$$\Delta y_A = 11,48 \text{ m}$$

When A is at highest point
Wanneer A op hoogste punt is

$$\Delta y_B = v_i \Delta t + \frac{1}{2} a \Delta t^2$$

$$= 0 + \frac{1}{2} (-9,8) (1,53)^2 \checkmark \checkmark$$

$$\Delta y_B = -11,47 \text{ m}$$

$$\Delta y_B = 11,47 \text{ m downward/afwaarts}$$

$$\text{Distance/Afstand} = y_A + y_B$$

$$= 11,47 + 11,48 \checkmark$$

$$= 22,95 \text{ m} \checkmark$$

Downwards positive/Afwaarts positief:

$$v_f^2 = v_i^2 + 2a\Delta y \checkmark$$

For ball A/Vir bal A

$$0 = (-15)^2 \checkmark + 2(9,8)\Delta y \checkmark$$

$$\Delta y_A = -11,48 \text{ m}$$

When A is at highest point
Wanneer A op hoogste punt is

$$\Delta y_B = v_i \Delta t + \frac{1}{2} a \Delta t^2$$

$$= 0 + \frac{1}{2} (9,8) (1,53)^2 \checkmark \checkmark$$

$$\Delta y_B = 11,47 \text{ m}$$

$$\Delta y_B = 11,47 \text{ m downward/afwaarts}$$

$$\text{Distance/Afstand} = y_A + y_B$$

$$= 11,48 + 11,47 \checkmark$$

$$= 22,95 \text{ m} \checkmark$$

(7)

Notes/Aantekeninge

Accept/Aanvaar
g or/of a
 $\Delta x = v_i \Delta t + \frac{1}{2} a \Delta t^2 \checkmark$
 $s = ut + \frac{1}{2} at^2$

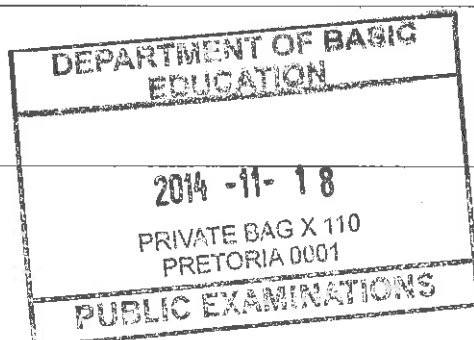

Handwritten signatures and initials: R.E., P.N., B, and a stylized signature.

OPTION 2/OPSIE 2	
Upwards positive/Opwaarts positief:	Downwards positive/Afwaarts positief:
<u>At maximum height $v_f = 0$:</u> <u>By maksimum hoogte $v_f = 0$:</u>	<u>At maximum height $v_f = 0$:</u> <u>By maksimum hoogte $v_f = 0$:</u>
Ball/Bal A $\Delta y_A = v_i \Delta t + \frac{1}{2} a \Delta t^2 \checkmark$ $= 15 (1,53) \checkmark + \frac{1}{2} (-9,8) (1,53)^2 \checkmark$ $= 11,48 \text{ m}$	Ball/Bal A $\Delta y_A = v_i \Delta t + \frac{1}{2} a \Delta t^2 \checkmark$ $= (-15) (1,53) \checkmark + \frac{1}{2} (9,8) (1,53)^2 \checkmark$ $= -11,48 \text{ m}$
<u>When A is at highest/point</u> <u>Wanneer A op hoogste punt is</u>	<u>When A is at highest point</u> <u>Wanneer A by hoogste punt is</u>
$\Delta y_B = v_i \Delta t + \frac{1}{2} a \Delta t^2$ $= 0 + \frac{1}{2} (-9,8) (1,53)^2 \checkmark \checkmark$ $\Delta y_B = -11,47 \text{ m}$ $\Delta y_B = 11,47 \text{ m downward/afwaarts}$	$\Delta y_B = v_i \Delta t + \frac{1}{2} a \Delta t^2$ $= 0 + \frac{1}{2} (-9,8) (1,53)^2 \checkmark \checkmark$ $\Delta y_B = -11,47 \text{ m}$ $\Delta y_B = 11,47 \text{ m downward/afwaarts}$
Distance/Afstand = $y_A + y_B$ $= 11,48 + 11,47 \checkmark$ $= 22,95 \text{ m} \checkmark$	Distance/Afstand = $(y_A + y_B)$ $= 11,48 + 11,47 \checkmark$ $= 22,95 \text{ m} \checkmark$

(7)

Notes/Aantekeninge**Accept/Aanvaar**

g or/of a

 $v = u + at$

OPTION 3/OPSIE 3	
Upwards positive/Opwaarts positief:	Downwards positive/Afwaarts positief:
Ball A/Bal A $\Delta y_A = v_i \Delta t + \frac{1}{2} a \Delta t^2 \checkmark$ $\Delta y_A = 15(1,53) \checkmark + \frac{1}{2} (-9,8) (1,53)^2 \checkmark$ $= 11,48 \text{ m}$	Ball A/Bal A $y_A = v_i \Delta t + \frac{1}{2} a \Delta t^2 \checkmark$ $\Delta y_A = -15 (1,53) \checkmark + \frac{1}{2} (9,8) (1,53)^2 \checkmark$ $= -11,48 \text{ (m)}$ $= 11,48 \text{ m upward/opwaarts}$
For ball B/Vir bal B $v_f = v_i + a \Delta t$ $v_f = 0 + (-9,8)(1,53)$ $v_f = 14,99 \text{ m} \cdot \text{s}^{-1}$	For ball B/Vir bal B $v_f = v_i + a \Delta t$ $v_f = 0 + (9,8)(1,53)$ $v_f = 14,99 \text{ m} \cdot \text{s}^{-1}$
$v_f^2 = v_i^2 + 2a \Delta x$ $14,99^2 \checkmark = 0 + 2(-9,8) \Delta y_B \checkmark$ $\Delta y_B = -11,47 \text{ (m)}$ $= 11,47 \text{ m downward/afwaarts}$	$v_f^2 = v_i^2 + 2a \Delta x$ $14,99^2 \checkmark = 0 + 2(9,8) \Delta y_B \checkmark$ $\Delta y_B = 11,47 \text{ (m)}$
Distance/Afstand = $(y_A + y_B)$ $= 11,48 + 11,47 \checkmark$ $= 22,95 \text{ m} \checkmark$	Distance/Afstand = $(y_A + y_B)$ $= 11,48 + 11,47 \checkmark$ $= 22,95 \text{ m} \checkmark$

(7)

DEPARTMENT OF BASIC
EDUCATION

2014 -11- 18

PRIVATE BAG X 110
PRETORIA 0001

PUBLIC EXAMINATIONS

P.W.

Notes/Aantekeninge

When it returns to same level its speed is $15 \text{ m}\cdot\text{s}^{-1}$ / Wanneer dit na dieselfde vlak terugkeer is sy spoed $15 \text{ m}\cdot\text{s}^{-1}$.

Accept/Aanvaar

g or/of a

$$v = u + at$$

OPTION 4/OPSIE 4**Upwards positive/Opwaarts positief:**

Ball A/Bal A

$$\Delta y_A = \frac{v_i + v_f}{2} \Delta t \checkmark = \frac{(15 + 0)}{2} (1,53) \checkmark$$

$$= 11,48 \text{ m}$$

For ball B/Vir bal B

$$v_f = v_i + a\Delta t$$

$$= 0 + (-9,8) (1,53)$$

$$= -15 \text{ m}\cdot\text{s}^{-1}$$

$$\Delta y = \frac{v_i + v_f}{2} \Delta t = \frac{(0 - 15) \times 1,53}{2} \checkmark$$

$$= -11,47 \text{ m}$$

$$= 11,47 \text{ m downward/afwaarts}$$

$$\text{Distance/Afstand} = (y_A + y_B)$$

$$= 11,48 + 11,47 \checkmark$$

$$= 22,95 \text{ m} \checkmark$$

Downwards positive/Afwaarts positief:

Ball A/Bal A

$$\Delta y_A = \frac{v_i + v_f}{2} \Delta t \checkmark = \frac{(-15 + 0)}{2} (1,53) \checkmark$$

$$= -11,48 \text{ (m)}$$

$$= 11,48 \text{ m upwards/opwaarts}$$

$$v_f = v_i + a\Delta t$$

$$= 0 + (9,8) (1,53)$$

$$= 15 \text{ m}\cdot\text{s}^{-1}$$

$$\Delta y = \frac{v_i + v_f}{2} \Delta t = \frac{(0 + 15) \times 1,53}{2} \checkmark$$

$$= 11,47 \text{ m}$$

$$\text{Distance/Afstand} = y_A + y_B$$

$$= 11,48 + 11,47 \checkmark$$

$$= 22,95 \text{ m} \checkmark$$

(7)

Notes/Aantekeninge**Accept/Aanvaar**

g or/of a

$$v = u + at$$

$$s = \frac{u + v}{2} t$$

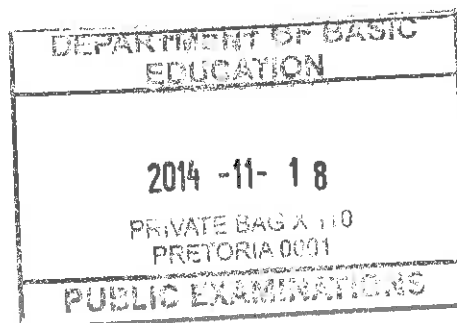

P.N.

P.N.

P.N.

<u>OPTION 5/OPSIE 5</u>	<u>OPTION 5/OPSIE 5</u>
<p>Upwards positive/Opwaarts positief:</p> <p>Ball A/Bal A $W_{\text{net}} = \Delta K \checkmark$</p> <p>OR/OF $\frac{1}{2} m (v_f^2 - v_i^2) = mg(h_f - h_i) \cos \theta$ $\frac{1}{2} m (0 - 15^2) \checkmark = m(9,8)h_f \cos 180^\circ \checkmark$ $h = 11,48 \text{ m}$</p> <p>OR/OF For Ball B when A is at highest point./ Vir Bal B wanneer A by sy hoogste punt is.</p> <p>$v_f = v_i + a\Delta t$ $= 0 + (-9,8)(1,53) = -15 \text{ m}\cdot\text{s}^{-1}$</p> <p>$\Delta y = \frac{v_i + v_f}{2} \Delta t = \frac{(0 - 15) \times 1,53}{2} \checkmark$ $= -11,48 \text{ m}$ $= 11,48 \text{ m downward/afwaarts}$</p> <p>Distance/Afstand = $y_A + y_B$ $= 11,48 + 11,48 \checkmark$ $= 22,96 \text{ m} \checkmark$</p>	<p>Downwards positive/Afwaarts positief:</p> <p>Ball A/Bal A $W_{\text{net}} = \Delta K \checkmark$</p> <p>OR/OF $\frac{1}{2} m (v_f^2 - v_i^2) = mg(h_f - h_i) \cos \theta$ $\frac{1}{2} m (0 - 15^2) \checkmark = m(9,8)h_f \cos 180^\circ \checkmark$ $h = 11,48 \text{ m}$</p> <p>OR/OF For Ball B when A is at highest point./ Vir Bal B wanneer A by sy hoogste punt is.</p> <p>$v_f = v_i + a\Delta t$ $= 0 + (9,8)(1,53) = 15 \text{ m}\cdot\text{s}^{-1}$</p> <p>$\Delta y = \frac{v_i + v_f}{2} \Delta t = \frac{(0 + 15)(1,53)}{2} \checkmark$ $= 11,48 \text{ m downward/afwaarts}$</p> <p>Distance/Afstand = $y_A + y_B$ $= 11,48 + 11,48 \checkmark$ $= 22,96 \text{ m} \checkmark$</p>

(7)

Notes/Aantekeninge
 Accept all the other options for calculating the height of ball B when this option is used to determine the maximum height of A.
 Aanvaar al die ander opsies vir die berekening van die hoogte van bal B wanneer hierdie opsie gebruik word om die maksimum hoogte van A te bepaal.

OPTION 6/OPSIE 6
 Any of the above calculations for calculating the maximum height ball A reaches. (2 marks)
 Enige van die bogenoemde berekeninge vir die berekening van maksimum hoogte wat bal A bereik. (2 punte)

- Ball B takes same time as Ball A ✓ / bal B neem dieselfde tyd as bal A
- Since acceleration is constant ✓ / Aangesien versnelling constant is
- Δy for ball A is the same as that for B ✓ / Δy vir bal A is dieselfde as dié vir bal B
- Ball A travels 11,48 m in this time ∴ B also travels 11,48 m ✓ / Ball A beweeg 11,48 m in hierdie tyd ∴ B beweeg ook 11,48 m
- Distance between A and B = 22,96 m / Afstand tussen A en B = 22,96m

(7)

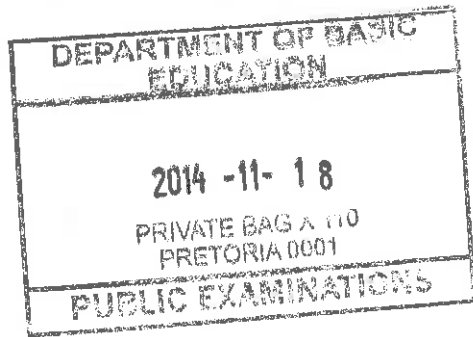

BCN P.N

OPTION 7/OPSIE 7	
<p>Upwards positive/Opwaarts positief: Ball A $\frac{1}{2} m v_i^2 + mgh_i = \frac{1}{2} m v_f^2 + mgh_f \checkmark$ $\frac{1}{2} m(15^2) \checkmark + 0 = \frac{1}{2} m(0) + m(9,8)h \checkmark$ $h = 11,48 \text{ m}$</p> <p>OR/OF For Ball B when A is at highest point. Vir Bal B wanneer A by sy hoogste punt is.</p> <p>$v_f = v_i + a\Delta t$ $= 0 + (-9,8)(1,53)$ $= -15 \text{ m}\cdot\text{s}^{-1}$</p> <p>$\Delta y = \frac{v_i + v_f}{2} \Delta t$ $= \frac{(0 - 15)(1,53) \checkmark}{2}$ $= -11,48 \text{ m}$ $= 11,48 \text{ m downward/afwaarts}$</p> <p>Distance/Afstand = $y_A + y_B$ $= 11,48 + 11,48 \checkmark$ $= 22,96 \text{ m} \checkmark$</p>	<p>Downwards positive/Afwaarts positief: Ball A $\frac{1}{2} m v_i^2 + mgh_i = \frac{1}{2} m v_f^2 + mgh_f \checkmark$ $\frac{1}{2} m(15^2) \checkmark + 0 = \frac{1}{2} m(0) + m(9,8)h \checkmark$ $h = 11,48 \text{ m}$</p> <p>OR/OF For Ball B when A is at highest point. Vir Bal B wanneer A by sy hoogste punt is.</p> <p>$v_f = v_i + a\Delta t$ $= 0 + (9,8)(1,53)$ $= 15 \text{ m}\cdot\text{s}^{-1}$</p> <p>$\Delta y = \frac{v_i + v_f}{2} \Delta t$ $= \frac{(0 + 15)(1,53) \checkmark}{2}$ $= 11,48 \text{ m downward/afwaarts}$</p> <p>Distance/Afstand = $y_A + y_B$ $= 11,48 + 11,48 \checkmark$ $= 22,96 \text{ m} \checkmark$</p>

(7)

Notes/Aantekeninge

Accept/Aanvaar

$\Delta K + \Delta U = 0$ (when/as $W_{nc} = 0$)

$\frac{1}{2} m(v_f^2 - v_i^2) + mg(h_f - h_i) = 0$

Accept all other options for calculating the height of ball B when this option is used to determine maximum height of A

Aanvaar aal die ander opsies vir die berekening van die hoogte van bal B wanneer hierdie opsie gebruik word om die maksimum hoogte van bal B wanneer hierdie opsie gebruik word om die maksimum hoogte van A te bepaal.

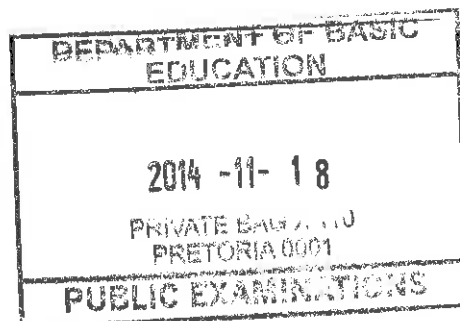

PC
P.N
S
S

3.4 **POSITIVE MARKING FROM QUESTION 3.2/POSITIEWE NASIEN VANAF VRAAG 3.2.**
CONSIDER MOTION UPWARD AS POSITIVE/BESKOU BEWEGING OPWAARTS AS POSITIEF

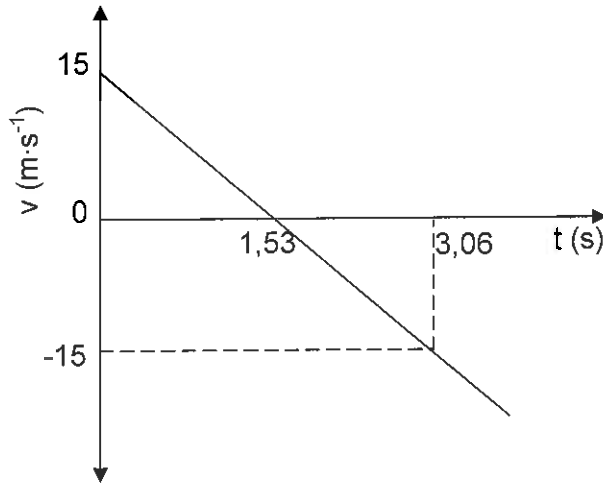

(4)
[17]

CONSIDER MOTION DOWNWARD AS POSITIVE/BESKOU BEWEGING AFWAARTS AS POSITIEF

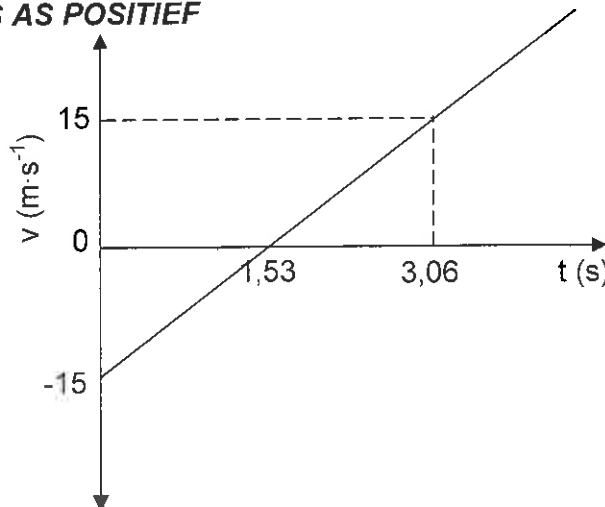

Criteria/Kriteria	Marks/Punte
Graph starts at correct Initial velocity shown./Grafiek begin by korrekte beginsnelheid aangetoon.	✓
Time for maximum height shown (1,53 s)./Tyd vir maksimum hoogte aangetoon.(1,53 s)	✓
Time for return shown (3,06 s) /Tyd om terug te keer (3,06) aangetoon.	✓
Shape/Vorm: Straight line extending beyond 3,06 s/ Reguitlyn wat verby 3,06 s strek.	✓

(4)
[17]

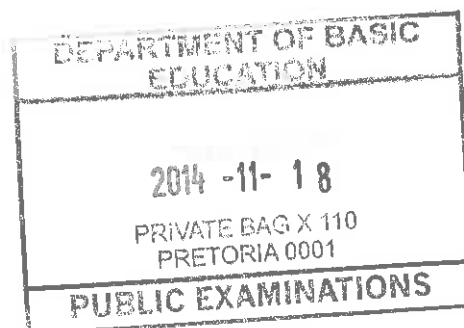

Handwritten signatures and initials: P.N., Z, and another signature.

QUESTION 4/VRAAG 4

4.1 $p = mv\checkmark$
 $= 50(5)\checkmark$
 $= 250 \text{ kg}\cdot\text{m}\cdot\text{s}^{-1}\checkmark$ (downward/afwaarts)

OR/OF

$p = mv\checkmark$
 $= 50(-5)\checkmark$
 $= -250 \text{ kg}\cdot\text{m}\cdot\text{s}^{-1}$
 $= 250 \text{ kg}\cdot\text{m}\cdot\text{s}^{-1}\checkmark$ (downward/afwaarts) (3)

4.2 The product of the (net) force and the time interval (during which the force acts) $\checkmark\checkmark$ (2 or 0)
 Die produk van die (netto) krag en die tydinterval (waartydens die krag inwerk) (2 of 0). (2)

4.3

OPTION 1/OPSIE 1 $\Delta p = F_{\text{net}}\Delta t\checkmark$ $0 - 250 \checkmark = F_{\text{net}}(0,2)$ $F_{\text{net}} = -1\,250 \text{ N}$ $= 1\,250 \text{ N} \checkmark$	$\Delta p = F_{\text{net}}\Delta t\checkmark$ $250 - 0 \checkmark = F_{\text{net}}(0,2)$ $F_{\text{net}} = 1\,250 \text{ N} \checkmark$	$\Delta p = F_{\text{net}}\Delta t\checkmark$ $50(0 - (-5))\checkmark = F_{\text{net}}(0,2)$ $F_{\text{net}} = 1\,250 \text{ N} \checkmark$
---------------------------------------------------------------------------------------------------------------------------------------------------------------------------------------------------	-----------------------------------------------------------------------------------------------------------------------------------------------	---------------------------------------------------------------------------------------------------------------------------------------------------

(3)

OPTION 2/OPSIE 2 $m(v_f - v_i) = F_{\text{net}}\Delta t\checkmark$ $50(0 - 5) \checkmark = F_{\text{net}}(0,2)$ $F_{\text{net}} = -1\,250 \text{ N}$ $= 1\,250 \text{ N} \checkmark$	$m(v_f - v_i) = F_{\text{net}}\Delta t\checkmark$ $50(5 - 0) \checkmark = F_{\text{net}}(0,2)$ $F_{\text{net}} = 1\,250 \text{ N} \checkmark$
---------------------------------------------------------------------------------------------------------------------------------------------------------------------------------------------------------	-----------------------------------------------------------------------------------------------------------------------------------------------------

(3)

Notes/Aantekeninge
 Accept/Aanvaar
 $m(v - u) = F_{\text{net}} \Delta t$

OPTION 3 /OPSIE 3 $v_f = v_i + a\Delta t$ $0 = 5 + a(0,2) \checkmark$ $a = -25 \text{ m}\cdot\text{s}^{-2}$ $F_{\text{net}} = ma\checkmark$ $= 50(-25)$ $= -1\,250 \text{ N}$ $= 1\,250 \text{ N} \checkmark$	$v_f = v_i + a\Delta t$ $5 = 0 + a(0,2) \checkmark$ $a = 25 \text{ m}\cdot\text{s}^{-2}$ $F_{\text{net}} = ma\checkmark$ $= 50(25)$ $= 1\,250 \text{ N} \checkmark$
-------------------------------------------------------------------------------------------------------------------------------------------------------------------------------------------------------------------------------------------	------------------------------------------------------------------------------------------------------------------------------------------------------------------------------------

(3)

Notes/Aantekeninge
 Accept/Aanvaar
 $v = u + at$

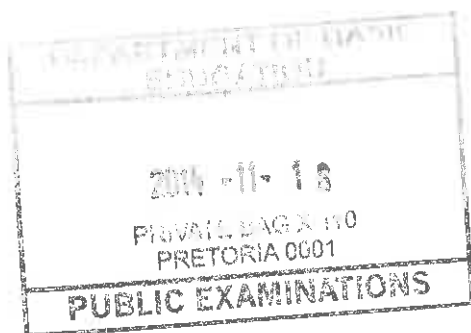

Handwritten signatures and initials: BCR, P.N., and other marks.

4.4 Greater than/Groter as ✓

(1)

4.5 For the same momentum change, ✓
the stopping time (contact time) ✓ will be smaller (less) ✓
∴ the (upward) force exerted (on her) is greater.

Vir dieselfde verandering in momentum,

sal die stilhou tyd (kontaktyd) kleiner wees

∴ die (opwaartse) krag wat (op haar) uitgeoefen word, sal groter wees.

(3)
[12]

Notes/Aantekeninge

Accept/Aanvaar

Since $F_{\text{net}} = \frac{\Delta p}{\Delta t}$ the force is great when the stopping time ✓ is smaller (less) ✓

Since change in momentum is the same for both jumps ✓ F_{net} increases.

Aangesien $F_{\text{net}} = \frac{\Delta p}{\Delta t}$, is die krag groot indien die stilhou tyd klein is. Aangesien die

verandering in momentum dieselfde is vir beide spronge sal F_{net} toeneem

QUESTION 5/VRAAG 5

5.1.1 In an isolated/closed system, ✓ the total mechanical energy is conserved / remains constant ✓

In 'n geïsoleerde/geslote sisteem bly die totale meganiese energie behoue / bly konstant.

OR/OF

The total mechanical energy of a system is conserved/ remains constant ✓ in the absence of friction. ✓

Die totale meganiese energie van 'n sisteem bly behoue/bly konstant in die afwesigheid van wrywing.

OR/OF

The total mechanical energy of a system remains constant ✓ provided the net work done by external non conservative forces is zero. ✓

Die totale meganiese energie van 'n sisteem bly konstant, mits die arbeid verrig deur eksterne nie-konserwatiewe kragte, nul is.

OR/OF

In the absence of a non-conservative force, the total mechanical energy is conserved/remains constant

In die afwesigheid van 'n nie-konserwatiewe krag, bly die totale meganiese energie behoue / konstant

OR/OF

In an isolated/closed system, ✓ the sum of kinetic and gravitational potential energy is conserved / remains constant ✓

In 'n geïsoleerde/geslote sisteem bly som van kinetiese en gravitasionele potensiële energie behoue / bly konstant.

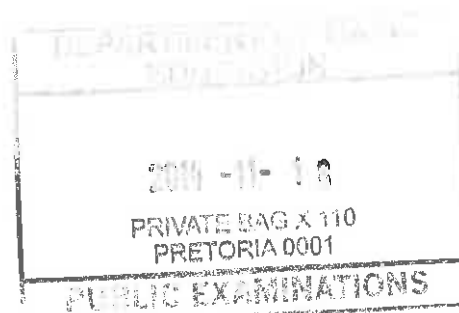

Notes/Aantekeninge:

Allocate mark for "isolated/closed system" only in conjunction with energy.
Ken punt toe vir "geïsoleerde/geslote sisteem" slegs indien saam met energie gebruik.

(2)

5.1.2 No/Need ✓

(1)

5.1.3 **OPTION 1/OPSIE 1**

Along **AB/Langs AB**

$$\left. \begin{aligned} E_{\text{mechanical at A}} &= E_{\text{mechanical at B}} \\ (E_p + E_k)_A &= (E_p + E_k)_B \\ (mgh + \frac{1}{2}mv^2)_A &= (mgh + \frac{1}{2}mv^2)_B \\ (10)(9,8)(4) + 0 &= 0 + \frac{1}{2}(10)v_f^2 \\ v_f &= 8,85 \text{ m}\cdot\text{s}^{-1} \end{aligned} \right\} \checkmark$$

Along **AB/Langs AB**

$$\begin{aligned} W_{\text{net}} &= \Delta E_k \checkmark \\ F_g \Delta h \cos \theta &= \frac{1}{2}m(v_f^2 - v_i^2) \\ (10)(9,8)(4)\cos 0^\circ &= \frac{1}{2}(10)(v_f^2 - 0) \checkmark \\ v_f &= 8,85 \text{ m}\cdot\text{s}^{-1} \end{aligned}$$

Along **AB/Langs AB**

$$\begin{aligned} W_{\text{nc}} &= \Delta K + \Delta U \checkmark \\ 0 &= \frac{1}{2}(10)(v_f^2 - 0) + 10(9,8)(4 - 0) \checkmark \\ v_f &= 8,85 \text{ m}\cdot\text{s}^{-1} \end{aligned}$$

Substitute $8,85 \text{ m}\cdot\text{s}^{-1}$ in one of the following options
Vervang $8,85 \text{ m}\cdot\text{s}^{-1}$ in een van die volgende opsies

Along **BC/Langs BC**

$$\begin{aligned} W_{\text{net}} &= \Delta K \checkmark \\ f \Delta x \cos \theta &= \Delta K \\ \underline{f(8)\cos 180^\circ} \checkmark &= \underline{\frac{1}{2}(10)(0 - 8,85^2)} \checkmark \\ f &= 48,95 \text{ N} \checkmark \end{aligned}$$

Along **BC/Langs BC**

$$\begin{aligned} W_{\text{nc}} &= \Delta K + \Delta U \checkmark \\ f \Delta x \cos \theta &= \Delta K + \Delta U \\ \underline{f(8)\cos 180^\circ} \checkmark &= \underline{\frac{1}{2}(10)(0 - 8,85^2) + 0} \checkmark \\ f &= 48,95 \text{ N} \checkmark \text{ (Accept/ Aanvaar 49 N)} \end{aligned}$$

(6)

Notes/Aantekeninge

1 mark for having all underlined substitutions correct./ 1 punt vir al die onderstreepte wat korrek vervanging is.

OPTION 2/OPSIE 2

Along **AC/Langs AC**

$$\begin{aligned} W_{\text{nc}} &= \Delta K + \Delta U \checkmark \\ f \Delta x \cos \theta &= \Delta K + \Delta U \\ (f)(8) \checkmark (\cos 180^\circ) \checkmark &= (0 - 0) \checkmark + 10(9,8)(0 - 4) \checkmark \\ f &= 49 \text{ N} \checkmark \end{aligned}$$

(6)

5.2.1 $f_k = \mu_k N \checkmark$

$$\begin{aligned} &= \mu_k mg \cos \theta \\ &= \underline{(0,19)(300)(9,8) \cos 25^\circ} \checkmark \\ &= 506,26 \text{ N} \checkmark \end{aligned}$$

(3)

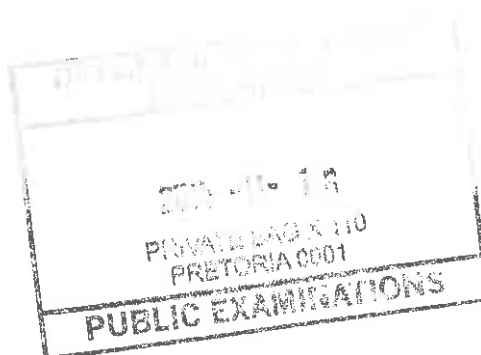

Handwritten signatures and initials, including 'P.N.' and other illegible marks.

Notes/Aantekeninge

If subscripts not shown award mark formula / Indien voetskrifte nie aangedui is nie, ken punte toe.

5.2.2 **POSITIVE MARKING FROM QUESTION 5.2.1**
POSITIEWE NASIEN VAN VRAAG 5.2.1

OPTION 1/OPSIE 1

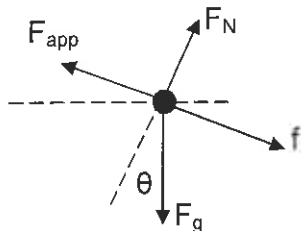

$$F_{net} = 0$$

$$F_{app} + (-F_g \sin \theta) + (-f) = 0$$

$$F_{app} - (300)(9,8) \sin 25^\circ - 506,26 = 0$$

$$F_{app} = 1\,748,76 \text{ N}$$

$$P_{ave} = F v_{ave}$$

$$= 1\,748,76 \times 0,5$$

$$= 874,38 \text{ W}$$

(6)

Notes/Aantekeninge

Do not penalise if free body diagram is not shown / Moenie penaliseer indien die vrye kragtediagram nie getoon is nie.

Do not penalise if $F_{app} - (F_g \sin \theta + f) = 0$ is not given / Moenie penaliseer indien

if $F_{app} = (300)(9,8) \sin 25^\circ + 506,26$ (3 marks / punte)

OPTION 2/OPSIE 2

$$W_f + W_{app} + W_N + W_g = 0$$

$$F \Delta x \cos \theta + F_{app} \Delta x \cos \theta + 0 + F_g \Delta x \cos \theta = 0$$

$$(506,26 \Delta x \cos 180^\circ) + (F_{app} \Delta x \cos 0) + 300(9,8) \Delta x \cos 115^\circ = 0$$

$$F_{app} = 1\,748,76 \text{ N}$$

$$P_{ave} = F v_{ave}$$

$$= (1\,748,76) (0,5)$$

$$= 874,38 \text{ W}$$

(6)

Notes/Aantekeninge

Do not penalise if free body diagram is not shown / Moenie penaliseer indien die vrye kragtediagram nie getoon is nie.

Do not penalise/ Moenie penaliseer if/indien $F_{app} - (F_g \sin \theta + f) = 0$ is not given /nie gegee is nie (3 marks / punte)

Do not penalise/ Moenie penaliseer if/indien $W_f + W_{app} + W_N + W_g = 0$ is not given /nie gegee is nie (3 marks / punte)

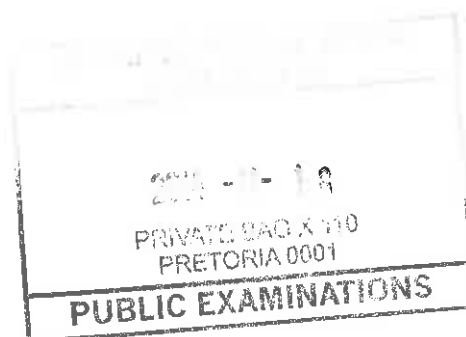

Handwritten signatures and initials: B.N., S., J.

ACCEPT/AANVAAR

$$P_{ave} = \frac{W}{\Delta t} = \frac{F \Delta x \cos \theta}{\Delta t} \checkmark$$

$$= \frac{(1748,76)(0,5)(1)}{1} \checkmark$$

$$= 874,38 \text{ W} \checkmark$$

OPTION 3/OPSIE 3

$$W_f + W_{app} + W_N + W_g = 0 \checkmark$$

$$F \Delta x \cos \theta + F_{app} \Delta x \cos \theta + 0 + F_g \sin \theta \Delta x \cos \theta = 0$$

$$(506,26 \Delta x \cos 0) \checkmark + (F_{app} \Delta x \cos 0) + 300 (9,8) \sin 25^\circ \Delta x \cos 180 \checkmark = 0$$

$$F_{app} = 1\,748,76 \text{ N}$$

$$P_{ave} = F v_{ave} \checkmark$$

$$= (1\,748,76)(0,5) \checkmark$$

$$= 874,38 \text{ W} \checkmark$$

(6)
[18]

ACCEPT/AANVAAR

$$P_{ave} = \frac{W}{\Delta t} = \frac{F \Delta x \cos \theta}{\Delta t} \checkmark$$

$$= \frac{(1748,76)(0,5)(1)}{1} \checkmark$$

$$= 874,38 \text{ W} \checkmark$$

QUESTION 6/VRAAG 6

6.1.1 An (apparent) change in observed/detected frequency (pitch), (wavelength) ✓ as a result of the relative motion between a source and an observer ✓ (listener).
'n Skynbare verandering in waargenome frekwensie (toonhoogte), (golflengte) as gevolg van die relatiewe beweging tussen die bron en 'n waarnemer/luisteraar. (2)

6.1.2 Towards/Na ✓

Observed/detected frequency is greater than the actual frequency. ✓
Waargenome frekwensie is groter as die werklike frekwensie. (2)

6.1.3 $f_L = \frac{v \pm v_L}{v \pm v_s} f_s$ **OR/OF** $f_L = \frac{v}{v - v_s} f_s$ ✓

$$(1200) \checkmark = \frac{343}{343 - v_s} \checkmark 1130 \checkmark$$

$$v_s = 20,01 \text{ m} \cdot \text{s}^{-1} \checkmark$$

Accept/Aanvaar: (19,42 – 20,01 m·s⁻¹)

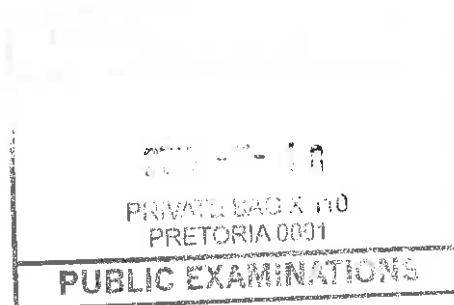

(5)

6.2 The star is approaching the earth. ✓
Die ster nader die aarde.

OR/OF

The earth and the star are approaching (moving towards) each other. ✓
Die aarde en die ster nader mekaar.

The spectral lines in diagram 2 are shifted towards the blue end/blue shifted. ✓
Die spektrumlyne in diagram 2 het verskuif na die blou ent/blou verskuiwing

(2)
[11]

Bev
P.N

Notes/Aantekeninge

Accept/Aanvaar

Shifted toward the left /the wavelengths of the corresponding spectral lines in diagram 2 are shorter (shifted). ✓ ✓

Verskuif na links/die golflengtes van die ooreenstemmende spektrumlyne in diagram 2 is korter (verskuif).

QUESTION 7/VRAAG 7

- 7.1 To ensure that charge does not leak to the ground/insulated. ✓
Om te verseker dat die lading nie na die grond toe lek nie/soleer. (1)

Notes/Aantekeninge

Accept/Aanvaar

In order retain original charge ✓/To insulate the charges./ Om oorspronklike lading te behou/ Om lading te isoleer.

- 7.2 Net charge/Netto lading = $\frac{Q_R + Q_S}{2} = \frac{+8 + (-4)}{2} \checkmark = 2 \mu\text{C} \checkmark$ (2)

- 7.3 **POSITIVE MARKING FROM QUESTION 7.2**
POSITIEWE NASIEN VANAF VRAAG 7.2

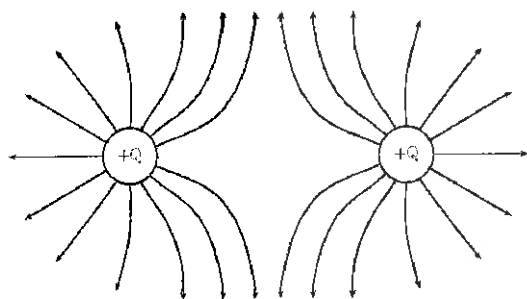

Criteria for sketch:/Kriteria vir skets:	Marks/ Punte
Correct direction of field lines Korrekte rigting van veldlyne	✓
Shape of the electric field Vorm van elektrieseveld	✓
No field line crossing each other / No field lines inside the spheres/ Geen veldlyne wat mekaar kruis nie / Geen veldlyne binne sfeer nie	✓

Accept / Aanvaar: pattern for point charges /patroon vir puntladings (3)

- 7.4 (2)

Notes/Aantekeninge

1 mark for forces correctly drawn with arrows. 1 punt vir kragte korrek aangedui met pyltjies

No labels/ Geen byskrifte 1 / 2

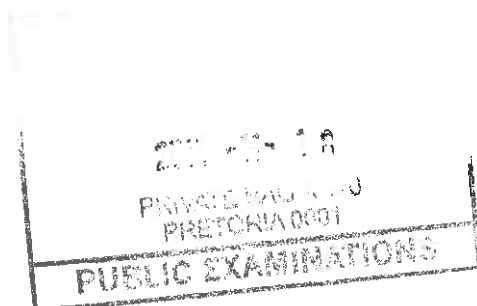

Handwritten signatures and initials, including 'B.C.', 'P.N.', and other illegible marks.

7.5 **POSITIVE MARKING FROM QUESTION 7.2**
POSITIEWE NASIEN VANAF VRAAG 7.2

2014 - 11 - 18
PRIVATE BAG X 110
PRETORIA 0001

PUBLIC EXAMINATIONS

OPTION 1/OPSIE 1

$$F = k \frac{Q_1 Q_2}{r^2} \checkmark$$

$$F_{ST} = (9 \times 10^9) \frac{(1 \times 10^{-6})(2 \times 10^{-6})}{(0,2)^2} \checkmark = 0,45 \text{ N} / 4,5 \times 10^{-1} \text{ N left/links}$$

OR/OF

$$F_{TS} = \frac{1}{4} F_{RT} = \frac{1}{4} (1,8) = 0,45 \text{ N}$$

$$F_{RT} = 9 \times 10^9 \times \frac{(2 \times 10^{-6})(1 \times 10^{-6})}{(0,1)^2} \checkmark = 1,8 \text{ N right/regs}$$

OR/OF

$$F_{RT} = 4F_{ST} = 4(0,45) = 1,8 \text{ N right /regs}$$

$$F_{\text{net}} = F_{ST} + F_{RT} = 1,8 + (-0,45) \checkmark$$

$$= 1,35 \text{ N or towards sphere S / na sfeer or/of right/regs S} \checkmark$$

(6)

Notes/Aantekeninge

If original charge of R and S is used / Indien oorspronklike lading van R en S gebruik is
Max/Maks $\frac{2}{6}$

Notes/Aantekeninge

For calculation of first force i.e. F_{ST} or F_{RT} award 2 marks / Vir berekening van eerste krag d.i. F_{ST} of F_{RT} keen 2 punte toe

1 mark correct conversion and substitution of denominator./ 1 punt vir korrekte omskakeling en vervanging in deler.

ACCEPT/AANVAAR

$F_{\text{left/links}}$ and/en $F_{\text{right/regs}}$

Final mark for both magnitude and direction / Finale punt vir beide grootte en rigting

OPTION 2/OPSIE 2

$$E_R = \frac{kQ}{r^2} = \frac{(9 \times 10^9)(2 \times 10^{-6})}{(0,1)^2} \checkmark = 1,8 \times 10^6 \text{ N.C}^{-1} \text{ right/regs}$$

$$E_s = \frac{kQ}{r^2} = \frac{(9 \times 10^9)(2 \times 10^{-6})}{(0,2)^2} \checkmark = 4,5 \times 10^5 \text{ N.C}^{-1} \text{ left/links}$$

$$E_{\text{net}} = 1,8 \times 10^6 - 4,5 \times 10^5 \checkmark = 1,35 \times 10^6 \text{ N.C}^{-1} \text{ right/regs}$$

$$F = EQ \checkmark = (1,35 \times 10^6)(1 \times 10^{-6}) \checkmark$$

$$= 1,35 \text{ N towards sphere S / na sfeer S right/regs} \checkmark$$



(6)

7.6 Force experienced \checkmark per unit positive charge \checkmark placed at that point.
Krag ondervind per eenheid positiewe lading by daardie punt.

(2)

ACCEPT/AANVAAR

Force \checkmark per unit positive charge \checkmark / Krag \checkmark per eenheid positiewe lading \checkmark .

P.S.  P.N. 

7.7 **POSITIVE MARKING FROM QUESTION 7.5**
POSITIEWE NASIEN VANAF VRAAG 7.5

OPTION 1/OPSIE 1

$$E = \frac{F}{q} \checkmark = \frac{1,35}{1 \times 10^{-6}} \checkmark = 1,35 \times 10^6 \text{ N}\cdot\text{C}^{-1} \checkmark$$

(3)

OPTION 2/OPSIE 2

$$E_R = \frac{kQ}{r^2} \checkmark = \frac{(9 \times 10^9)(2 \times 10^{-6})}{(0,1)^2} \checkmark = 1,8 \times 10^6 \text{ N}\cdot\text{C}^{-1} \text{ right/regs}$$

$$E_s = \frac{kQ}{r^2} = \frac{(9 \times 10^9)(2 \times 10^{-6})}{(0,2)^2} = 4,5 \times 10^5 \text{ N}\cdot\text{C}^{-1} \text{ left/links}$$

$$E_{\text{net}} = 1,8 \times 10^6 - 4,5 \times 10^5 = 1,35 \times 10^6 \text{ N}\cdot\text{C}^{-1} \checkmark$$

(3)

OPTION 3/OPSIE 3

$$E = \frac{F}{q} \checkmark = \frac{1,8}{1 \times 10^{-6}} \checkmark = 1,8 \times 10^6 \text{ N}\cdot\text{C}^{-1}$$

$$E = \frac{F}{q} = \frac{0,45}{1 \times 10^{-6}} = 4,5 \times 10^5 \text{ N}\cdot\text{C}^{-1}$$

$$E_{\text{net}} = 1,8 \times 10^6 - 4,5 \times 10^5 = 1,35 \times 10^6 \text{ N}\cdot\text{C}^{-1} \checkmark$$

(3)

[19]

QUESTION 8/VRAAG 8

8.1.1 Keep the temperature (of battery) constant.
Hou die temperatuur (van battery) konstant

(1)

8.1.2

Grafiek van potensiaalverskil teenoor stroom

Graph of potential difference vs current

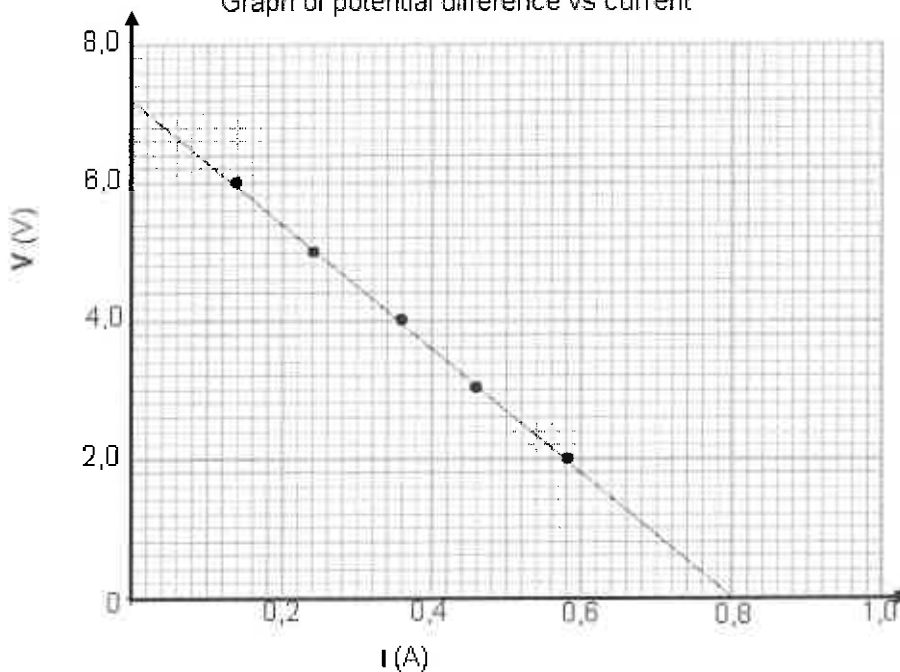

Handwritten signatures and initials: BE, P. N., and other scribbles.

Criteria for drawing line of best fit:/Kriteria vir teken van lyn van beste pas:	Marks/ Punte
ALL points correctly plotted (at least 4 points) <i>ALLE punte korrek gestip (ten minste 4 punte)</i>	✓✓
Correct line of best fit if all plotted points are used (at least 3 point) <i>Korrekte lyn van beste pas indien alle punte gebruik word (ten minste 3 punte)</i>	✓

Notes/Aantekeninge

If only 3 points are plotted correctly / Indien 3 punte korrek gestip is $\frac{1}{2}$

If the points are incorrectly plotted and the line of best fit is drawn

Indien die punte verkeerd gestip is en lyn van beste pas is geteken Max /Maks $\frac{1}{3}$

(3)

8.1.3 7,2 V✓

(Accept any readings between 7,0 V and 7,4 V or the value of the y-intercept
/Aanvaar enige lesing tussen 7,0 V en 7,4 V of die waarde van die y-afsnit

(1)

8.1.4 **POSITIVE MARKING FROM QUESTION 8.1.3**
POSITIEWE NASIEN VAN VRAAG 8.1.3

$$\begin{aligned} \text{Slope/Helling} &= \frac{\Delta V}{\Delta I} \\ &= \frac{0 - 7,2 \checkmark}{0,8 - 0 \checkmark} = -9 \\ r &= 9 \Omega \checkmark \end{aligned}$$

(3)

Notes/Aantekeninge

The final answer must be written for the last mark (must be positive)/ *Die finale antwoord moet geskryf word vir die laaste punt.*

Either the numerator must be negative (i.e. smaller value – larger value) or the denominator must be negative.

Of die teller moet negatief wees (d.i. kleiner waarde – groter waarde) of die noemer moet negatief wees.

Accept/Aanvaar:

Values between 8,3 Ω and 10,0 Ω / *Waardes tussen 8,3 Ω en 10,0 Ω*

8.2.1 **OPTION 1/OPSIE 1**

$$\begin{aligned} P &= VI \checkmark \\ 100 &= 20(I) \checkmark \\ I &= 5 \text{ A} \checkmark \end{aligned}$$

(3)

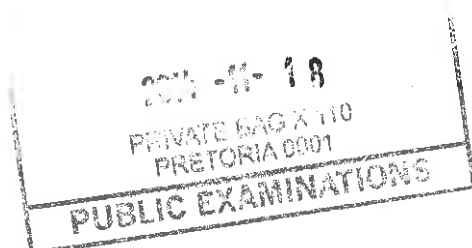

Handwritten initials and signatures: 'RC-', 'PN', and two stylized signatures.

<p><u>OPTION 2/OPSIE 2</u></p> $P = \frac{V^2}{R}$ $100 = \frac{(20)^2}{R}$ $R = 4 \Omega$ $V = IR$ $20 = I(4) \checkmark$ $I = 5 \text{ A} \checkmark$	<p>✓ Both formulae/Beide formule</p>
(3)	
<p><u>OPTION 3/OPSIE 3</u></p> $P = \frac{V^2}{R}$ $100 = \frac{(20)^2}{R}$ $R = 4 \Omega$ $P = I^2 R$ $100 = I^2(4) \checkmark$ $I = 5 \text{ A} \checkmark$	<p>✓ Both formulae/Beide formule</p>

8.2.2

<p><u>OPTION 1/OPSIE 1</u></p> $P = \frac{V^2}{R} \checkmark$ $R = \frac{(20)^2}{150} \checkmark$ $= 2,67 \Omega \checkmark$	
(3)	

<p><u>OPTION 2/OPSIE 2</u></p> $P = VI$ $150 = (20)I$ $I = 7,5 \text{ A}$ $V = IR$ $20 = (7,5)R \checkmark$ $R = 2,67 \Omega \checkmark$ <p>OR/OF</p> $P = I^2 R$ $150 = (7,5)^2 R \checkmark$ $R = 2,67 \Omega \checkmark$	<p>✓ Both formulae/Beide formule</p>
(3)	
<p><u>OPTION 3/OPSIE 3</u></p> $I_x : I_y$ $5 : 7,5$ $1 : 1,5$ $R_x : R_y$ $1,5 : 1 \checkmark$ $4 \checkmark : 2,67 \Omega \checkmark$	<p>(3)</p>

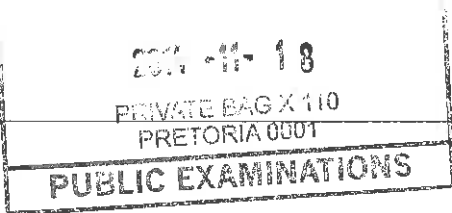

8.2.3 **POSITIVE MARKING FROM QUESTION 8.2.2.**
POSITIEWE NASIEN VAN VRAAG 8.2.2.

<p>OPTION 1/OPSIE 1 $P = VI$ $I_{150W} = \frac{150}{20} \checkmark = 7,5 \text{ A}$ $I_{\text{tot}} = (5 + 7,5) \checkmark$ $\varepsilon = I(R + r) \checkmark$ $24 = 12,5(R + r)$ $24 = V_{\text{ext}} + V_{\text{ir}}$ $24 = 20 + 12,5(r) \checkmark$ $r = 0,32 \Omega \checkmark$</p>	<p>OR/OF $P = I^2R$ $I_{150W} = \sqrt{\frac{150}{2,67}} \checkmark = 7,5 \text{ A}$</p>
-------------------------------------------------------------------------------------------------------------------------------------------------------------------------------------------------------------------------------------------------------------------------------------------------------------------------------------------------------------------------------------------------------------------------	--------------------------------------------------------------------------------------------------------------------------

(5)

<p>Notes/Aantekeninge 1 mark for one of the following / 1 punt vir een van die volgende $24 = 12,5(R + r)$ OR/OF $24 = V_{\text{ext}} + V_{\text{int}}$ OR/OF $24 = 20 + 12,5(r)$</p>

(5)

<p>OPTION 2/OPSIE 2 $V = Ir \checkmark$ $I_{\text{tot}} = (5 + 7,5) \checkmark$ $(24 - 20) \checkmark = 12,5 r \checkmark$ $\therefore r = \frac{4}{12,5}$ $r = 0,32 \Omega \checkmark$</p>

(5)

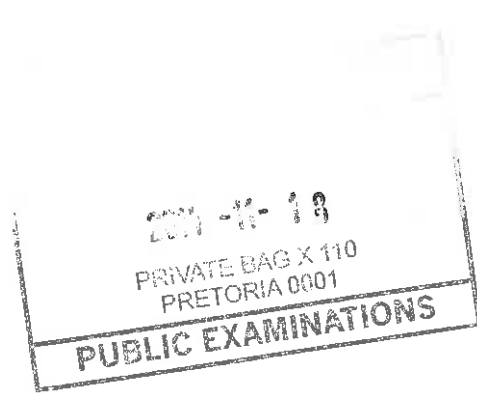

Handwritten initials and signatures: "BN", "P.N.", and two other illegible signatures.

8.2.3 POSITIVE MARKING FROM QUESTION 8.2.2
 POSITIEWE NASIEN VAN VRAAG 8.2.2.

OPTION 3/OPSIE 3

$$\frac{1}{R} = \frac{1}{R_1} + \frac{1}{R_2}$$

$$\frac{1}{R_{//}} = \frac{1}{4} + \frac{1}{2,67} \quad \text{OR/OF } R_{//} = \frac{(4)(2,67)}{4 + 2,67}$$

$$\therefore R_{//} = 1,6 \Omega$$

Note mark allocated for value of resistor X / *Let wel: punt toegeken vir waarde van resistor X*

$$I_{\text{tot}} = \frac{20}{1,6} = 12,5 \text{ A} \checkmark$$

$$\mathcal{E} = I(R + r) \checkmark$$

$$24 = 12,5(R + r)$$

$$24 = V_{\text{ext}} + V_r$$

$$24 = 20 + 12,5(r) \checkmark$$

$$r = 0,32 \Omega \checkmark$$

(5)

Notes/Aantekeninge

$$R_1 = R_x = \frac{400}{100}$$

$$R_1 = R_x = \frac{20}{5}$$

Accept/Aanvaar:

$$R_{//} = \frac{R_1 R_2}{R_1 + R_2}$$

$$\frac{1}{R} = \frac{1}{R_x} + \frac{1}{R_y}$$

2014-11-18
 PRIVATE BAG X 110
 PRETORIA 0001

PUBLIC EXAMINATIONS

1 mark for either of: /1 punt vir of

$$24 = 12,49(R + r)$$

$$24 = V_{\text{ext}} + V_r$$

OR/OF

$$24 = 20 + 12,49(r)$$

OPTION 4/OPSIE 4

$$P = VI \checkmark$$

$$250 = (20)I \checkmark$$

$$I = 12,5 \text{ A}$$

$$V = Ir \checkmark$$

$$4 = (12,5)r \checkmark$$

$$r = 0,32 \Omega \checkmark$$

(5)

Handwritten marks and signatures:
 A large checkmark-like symbol.
 The initials "P.N." written vertically.
 A signature that appears to be "R." followed by another signature.

- 8.2.4 Device Z is a voltmeter ✓.
Toestel Z is 'n voltmeter

(1)

Notes/Aantekeninge

Accept/Aanvaar:

Very high resistance device / Baie hoë weerstand toestel

- 8.2.5 Device Z should be a voltmeter (or a device with very high resistance) because it has a very high resistance ✓ and will draw very little current. ✓
The current through X and Y will remain the same hence the device can operate as rated.

Toestel Z moet 'n voltmeter wees (of 'n toestel met 'n baie hoë weerstand) omdat dit 'n baie hoë weerstand het en baie min sal stroom trek

Die stroom deur X en Y sal dieselfde bly, gevolglik kan die toestel werk soos ontwerp.

(2)

[22]

QUESTION 9/VRAAG 9

- 9.1 Electromagnetic induction / Elektromagnetiese induksie ✓

(1)

- 9.2 Rotate the coil faster/Increase the number of coils/ Increase the strength of the magnetic field.

Roteer die spoel vinniger/Verhoog die aantal spoele / Verhoog die sterkte van die magneetveld.

(1)

- 9.3 Slip rings/Sleepringe ✓

(1)

- 9.4.1 It is the value of the voltage in a DC circuit ✓ that will have the same heating effect as an AC circuit. ✓

Dit is die waarde van die potensiaalverskil in 'n GS-stroombaan ✓ wat dieselfde verhittingseffek het as 'n WS-stroombaan ✓

(2)

9.4.2 $V_{\text{rms}} = \frac{V_{\text{max}}}{\sqrt{2}}$ ✓

$= \frac{339,45}{\sqrt{2}}$ ✓

$V_{\text{rms}} = 240,03 \text{ V}$ ✓

Accept/Aanvaar (240,03 – 240,74)

(3)

[8]

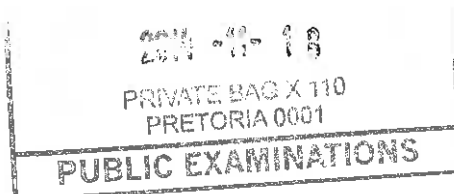

Handwritten signatures and initials, including 'P.N.' and 'D.A.'.

QUESTION 10/VRAAG 10

10.1 The minimum frequency (of a photon/light) needed to emit electrons ✓ from (the surface of) a metal. (substance) ✓
 Die minimum frekwensie (van 'n foton/lic) benodig om elektrone vanaf die (oppervlakte van)'n metaal (stof) vry te stel. (2)

10.2 **OPTION 1/OPSIE 1**

$$\begin{aligned}
 E &= W_o + E_{k(max)} \\
 E &= W_o + \frac{1}{2}mv_{max}^2 \\
 h\frac{c}{\lambda} &= hf_o + \frac{1}{2}mv_{max}^2 \\
 \frac{(6,63 \times 10^{-34})(3 \times 10^8)}{\lambda} &= (6,63 \times 10^{-34})(5,548 \times 10^{14}) + \frac{1}{2}(9,11 \times 10^{-31})(5,33 \times 10^5)^2 \\
 \lambda &= 4 \times 10^{-7} \text{ m}
 \end{aligned}$$

✓ Any one / Enige een (5)

OPTION 2/OPSIE 2

$$\begin{aligned}
 E &= W_o + E_{k(max)} \\
 E &= W_o + \frac{1}{2}mv_{max}^2 \\
 hf &= hf_o + \frac{1}{2}mv_{max}^2 \\
 (6,63 \times 10^{-34})f &= (6,63 \times 10^{-34})(5,548 \times 10^{14}) + \frac{1}{2}(9,11 \times 10^{-31})(5,33 \times 10^5)^2 \\
 f &= 7,5 \times 10^{14} \text{ Hz} \\
 c &= f\lambda \\
 3 \times 10^8 &= (7,5 \times 10^{14})\lambda \\
 \lambda &= 4 \times 10^{-7} \text{ m}
 \end{aligned}$$

✓ Any one / Enige een (5)

10.3 Smaller (less) than ✓
 Kleiner (minder) as (1)

10.4 The wavelength/frequency/energy of the incident light (photon/hf) is constant ✓.
 Die golflengte/frekwensie/energie van die invallende lig (foton/hf) is konstant

Since the speed is larger, the kinetic energy is larger ✓ the work function/W₀/threshold frequency smaller. ✓

Aangesien die spoed vergroot, is die kinetiese energie groter, is die arbeidsfunksie / W₀ / drumpel frekwensie kleiner (3)
 [11]

GRAND TOTAL/GROOTTOTAAL: 150

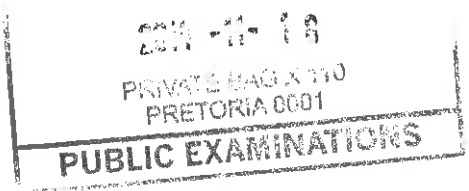

Handwritten initials: BA, P.N, S, D

ANNEXURE/AANHANGSEL

QUESTION 2 / VRAAG 2

2.1 Accept “unbalanced force” in the context of Newton’s Second Law
Aanvaar “omgebalanseerde krag” in die konteks van Newton se Tweede wet

2.2 **Accept/Aanvaar**

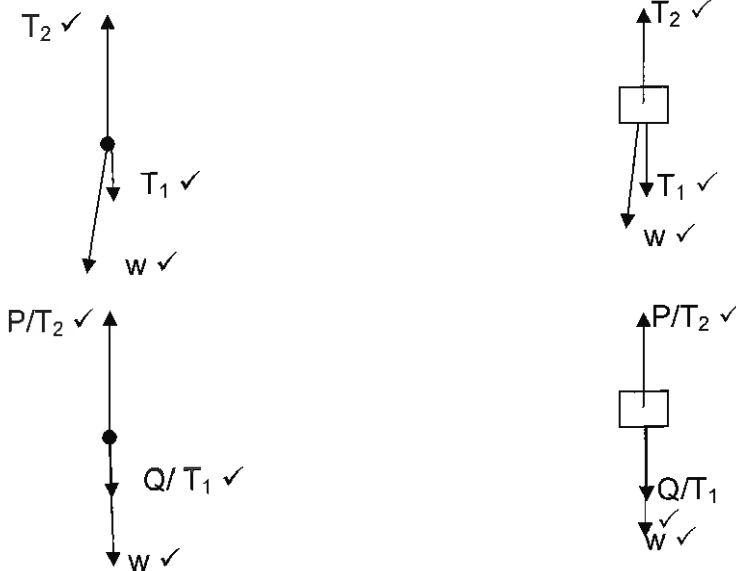

(3)

2.3

ACCEPT/AANVAAR

$F_{net} = ma$ ✓
 $T_2 - (M + m)g = (M + m)a$
 $250 - (25)(9,8) = 25a$ ✓
 $a = 0,2 \text{ m}\cdot\text{s}^{-2}$ ✓
 For 20 kg block/ Vir 20 kg blok

$T_1 + (-mg) = ma$(2)
 $T_1 = 20(9,8) + 20(0,2)$ ✓
 $T_1 = 200 \text{ N}$ ✓

(one mark for *leen punt vir 25 kg*)

(6)

ACCEPT/AANVAAR

$F_{net} = ma$ ✓
 $T_2 - (M + m)g = (M + m)a$
 $250 - (25)(9,8) = 25a$ ✓
 $a = 0,2 \text{ m}\cdot\text{s}^{-2}$ ✓
 For 5 kg block/ Vir 5 kg blok

$F_{net} = ma$
 $T_2 + F_g + T_1 = ma$
 $250 - (5)(9,8) + T_1 = 5(0,2)$ ✓
 $T_1 = -200 \text{ N}$
 $T_1 = 200 \text{ N}$ ✓

(one mark for *een punt vir 25 kg*)

(6)

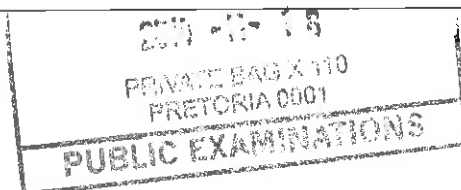

Handwritten signatures and initials: P.N., J, A.

QUESTION 3 / VRAAG 3

3.3

The distance between A and B can also be determined by using the graph in QUESTION 3.4 / Die afstand tussen A en B kan ook bepaal word deur die grafiek in VRAAG 3.4 te gebruik
 First part of graph is for ball A ✓ and the second part is for ball B ✓ / Eerste deel van grafiek is vir bal A en die tweede deel is vir bal B
 Distance = area between the graph and the x-axis ✓ / Afstand = area tussen grafiek en die x-as

$$= \frac{1}{2}bh + \frac{1}{2}bh \checkmark$$

$$= \frac{1}{2}(1,53)(15) \checkmark + \frac{1}{2}(1,53)(15) \checkmark$$

$$= 11,48 + 11,48$$

$$= 22,96 \text{ m } \checkmark$$

(7)

QUESTION 4 / VRAAG 4

4.2

Accept: Impulse is the change in momentum (2 or 0)
 Aanvaar: Impuls is die verandering in momentum (2 of 0)

(2)

QUESTION 7 / VRAAG 7

7.3

If electric field pattern for two equal opposite charges are drawn
 Indien elektriese veldpatroon vir twee gelyke teenoorgestelde ladings geteken is: Max/Maks $\frac{1}{3}$
 If electric pattern for two unequal opposite charges are drawn
 Indien elektriese veldpatroon vir twee ongelyke teenoorgestelde ladings geteken is: Max/Maks $\frac{2}{3}$

7.4

Accept / Aanvaar

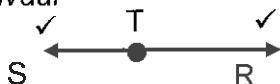

(2)

QUESTION 8 / VRAAG 8

8.2.4

Accept: rheostat / Open switch
 Aanvaar: reostaat / oop skakelar

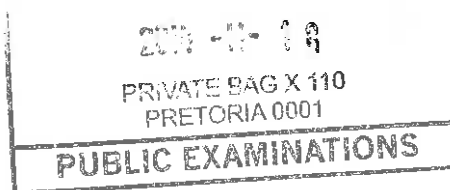

QUESTION 9 / VRAAG 9

9.4.1

Accept/Aanvaar

$V_{rms} = \frac{V_{max}}{\sqrt{2}}$ where V_{max} is the maximum (peak) voltage of the AC ✓✓

$V_{wgk} = \frac{V_{maks}}{\sqrt{2}}$ where V_{maks} is the maksimum (piek) spanning van die WS

Handwritten signatures and initials: P.N., S., D.